

HMP

HFR NUT

THIN HEIGHT NYLON INSERT ISO 10511

Definition: self-locking thin height nut with nylon insert

Threading: standard to ISO 965-2

Characteristic and performance test: for steel ISO 898-2 / ISO 2320
for stainless steel ISO 3506-2 / NF E 25035



d	pitch	h - min.	h - max.	m - min.	s
M 3	0,50	3,42	3,90	1,55	5,50
M 4	0,70	4,52	5,00	1,95	7,00
M 5	0,80	4,52	5,00	2,45	8,00
M 6	1,00	5,52	6,00	2,90	10,00
M 8	1,25	6,18	6,76	3,70	13,00
M 10	1,50	7,98	8,56	4,70	16,00
M 12	1,75	9,53	10,23	5,70	18,00
M 14	2,00	10,22	11,32	6,42	21,00
M 16	2,00	11,32	12,42	7,42	24,00
M 18	2,50	14,40	15,50	9,00	27,00
M 20	2,50	13,10	14,90	9,10	30,00
M 24	3,00	16,00	17,80	10,90	36,00
M 27	3,00	20,40	22,20	13,50	41,00
M 30	3,50	20,10	22,20	13,90	46,00
M 36	4,00	23,40	25,50	16,90	55,00

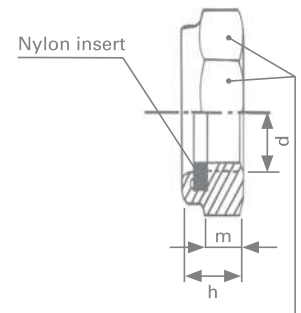

Marking of the class of the material and manufacturer's initials standard to the ISO 898-2

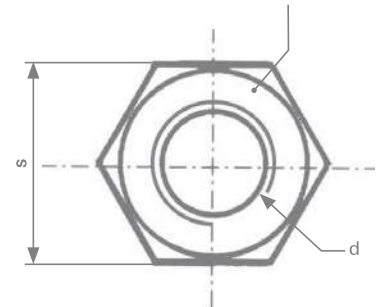

Quality class	Classification	Range of application	
Class 04 steel	QN	Standard Ring	Hi-Temp Ring
Class 05 steel	QS		
Stainless steel A2-70	ZE		
Stainless steel A4-70	ZK	-40° C +120° C	(1) -40° C +230° C (1)
Stainless steel A4-80	ZH		

(1) Values are only given as an indication

Surface treatment (standard to ROHS requirements)

Electroplated Zinc (steel)	Yellow	ZJ	ISO 4042
	Clear Lanthane ®	ZL	400 h
	Clear Lanthane ® + Topcoat	ZF	600 h
Zinc Flake (steel)	Geomet ®, Delta Protekt ®, Magni ®		600 / 1000h
Antigalling (stainless steel)	Stanal ® 400	ST	
	Sherardisation (NF EN 13811)	SH	
Plain Finish	Light Protective Oil	BT	

Example of ordering code

	Type	Diam X pitch	Class	Protection	
classification	HMP	100150	ZH	ST	00
wording	HMP	M10 X 1,50	A4 80	Stanal ®	*

* Standard size

On request: other materials, plating, sizes, imperial thread